

Uszczelnienia BW pomp Inoxpa Prolac

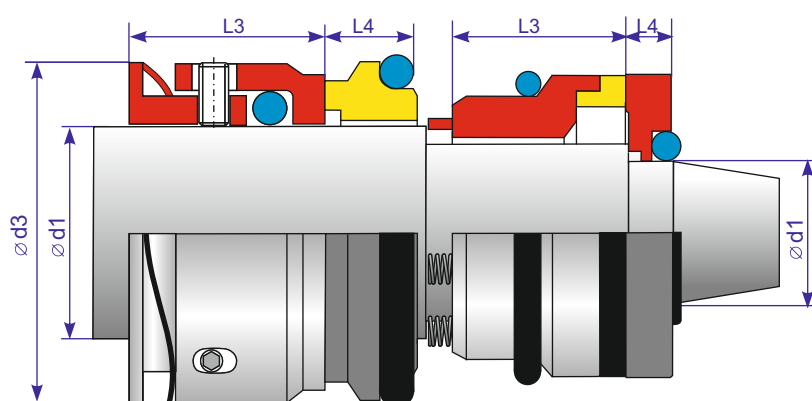

Typ uszczelnienia strona medium	Typ uszczelnienia strona płukana	Typ pompy:	Moc silnika kW	
			2900 obr/min	1450 obr/min
BWINOXPA 5/8" BSEGG	MPK/GG3 28mm SBEGG	S15A	0,37;0,55	0,25
BWINOXPA 1" BSEGG	MPK/GG3 35mm SBEGG	S20B,	1,1	0,75
BWINOXPA 1" BSEGG	MPK/GG3 35mm SBEGG	S20C	1,5;2,2	
BWINOXPA 1" BSEGG	MPK/GG3 35mm SBEGG	S28B	1,1	0,75
BWINOXPA 1" BSEGG	MPK/GG3 35mm SBEGG	S28C	1,5;2,2	
BWINOXPA 1" BSEGG	MPK/GG3 35mm SBEGG	S28E	3,0;4,0;5,5	
BWINOXPA 1" BSEGG	MPK/GG3 35mm SBEGG	S35C		1,5
BWINOXPA 1" BSEGG	MPK/GG3 50mm SBEGG	S35F	5,5;7,5;9,0;11,0	
BWINOXPA 1 1/2" BSEGG	MPK/GG3 50mm SBEGG	S38C(silnik typ 160)		1,5
BWINOXPA 1 1/2" BSEGG	MPK/GG3 50mm SBEGG	S38E(silnik typ 160)		2,2;3,0;4,0
BWINOXPA 1 1/2" BSEGG	MPK/GG3 50mm SBEGG	S38G(silnik typ 160)	11,0;15,0;18,5	
BWINOXPA 1 1/2" BSEGG	MPK/GG3 65mm SBEGG	S38H(silnik typ 160)	22,0	
BWINOXPA 1 1/2" BSEGG	MPK/GG3 65mm SBEGG	S38J(silnik typ 160)	30,0	
BWINOXPA 1 1/2" BSEGG	MPK/GG3 50mm SBEGG	S70F(silnik typ 160)		5,5;7,5;9,0
BWINOXPA 1 1/2" BSEGG	MPK/GG3 50mm SBEGG	S70G(silnik typ 160)	11,0;15,0;18,5	11,0;15,0
BWINOXPA 1 1/2" BSEGG	MPK/GG3 65mm SBEGG	S70H(silnik typ 160)	22,0	
BWINOXPA 1 1/2" BSEGG	MPK/GG3 65mm SBEGG	S70J(silnik typ 160)	30,0;37,0	
BWINOXPA 1 1/2" BSEGG	MPK/GG3 65mm SBEGG	S70K(silnik typ 160)	45,0	
BWINOXPA 1 1/2" BSEGG	MPK/GG3 50mm SBEGG	S80G(silnik typ 160)		11,0;15,0
BWINOXPA 1 1/2" BSEGG	MPK/GG3 65mm SBEGG	S80H(silnik typ 160)		18,5;22,0
BWINOXPA 1 1/2" BSEGG	MPK/GG3 65mm SBEGG	S80J(silnik typ 160)		30,0
BWINOXPA 1 1/2" BSEGG	MPK/GG3 85mm SBEGG	S80K(silnik typ 160)		37,0;45,0
BWINOXPA 1 1/2" BSEGG	MPK/GG3 85mm SBEGG	S80L(silnik typ 160)		55,0

BW Polska Dębica Sp. z o.o. Mościckiego 50A 39-200 Dębica tel:014 67 69 500 fax:014 67 69 501 e-mail:bwdebica@wp.pl NIP 872-24-05-874

